



Cooler By Design.™



Howden

A Chart Industries Company

Peter Gerstl

Brussels, 22nd November 2023

Powering the

N E X U S O F C L E A N™

We are Chart

Internal use



It all adds up



64

The number of manufacturing sites globally



50

The number of countries we operate in



169

The number of countries our products are installed in



50

The number of repair and service sites globally



1500+

Engineers on our team



1000+

Trademarks and patents held

Hydrogen Liquefaction – Layout

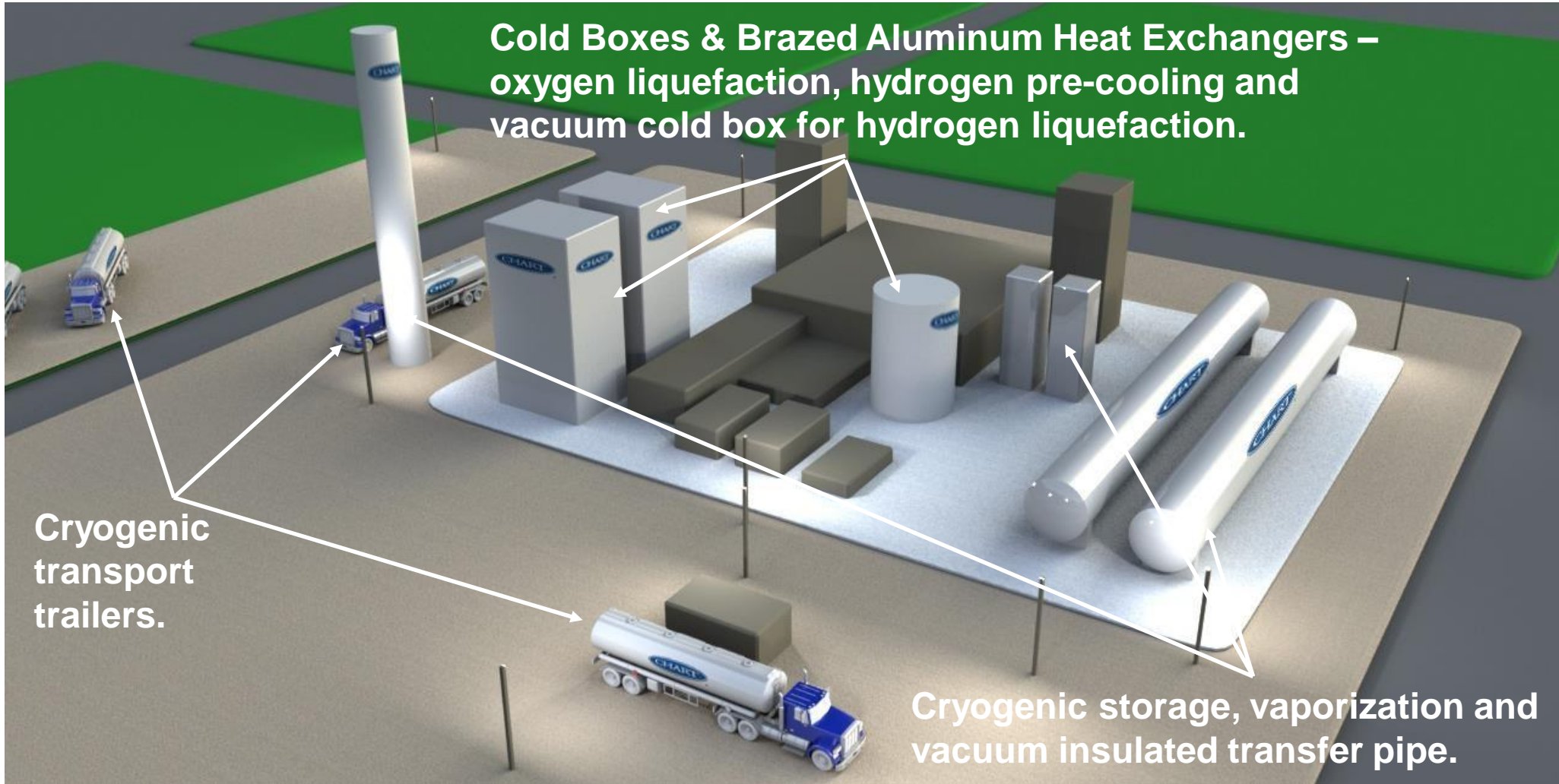

Transport of Hydrogen

Liquid Hydrogen:

- Semi-Trailer for 3.7 tons

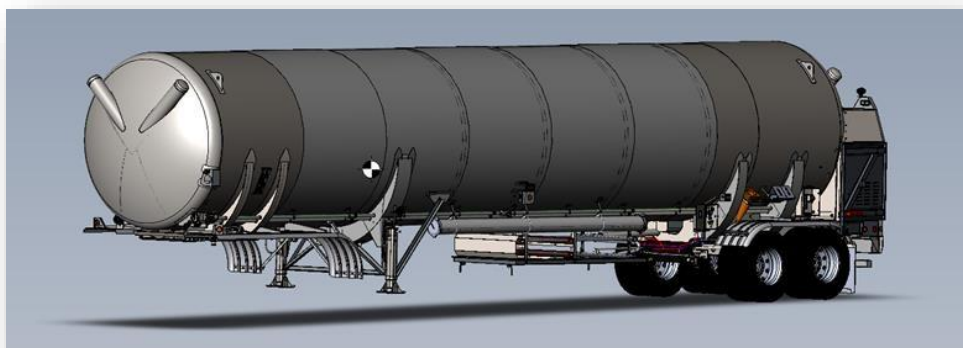

Liquid Hydrogen:

- 40ft ISO Container for 3.0 tons
- 30 days holding time
- Approvals for ship, road, rail

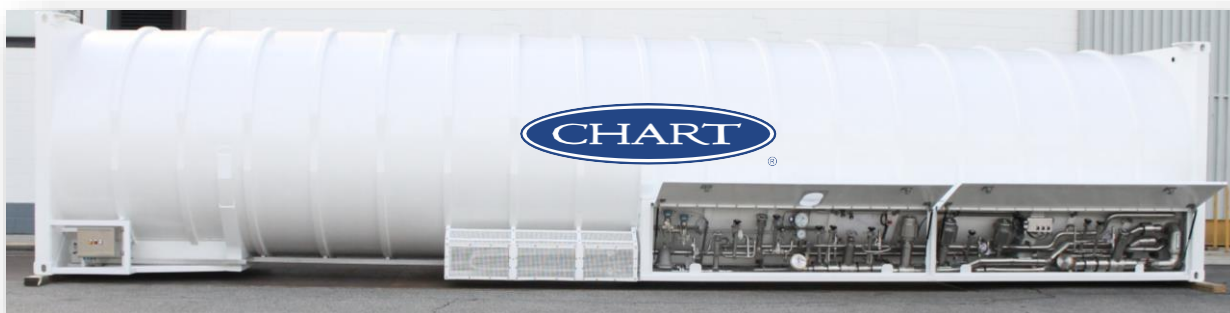

Gaseous Hydrogen:

- Semi-Trailer for 973 kg to 1.464 kg)



	300 bar	380 bar	500 bar	640 bar
Amount of Cylinders	133	83	122	112
Capacity	46.550 l	51.875 l	40.870 l	39.200 l
Payload (20° degree)	973 kg	1.313 kg	1.335 kg	1.464 kg

Hydrogen Refueling Station

Liquid Hydrogen Refueling:

- Liquid-to-Liquid Refueling
- Semi-mobile (skidded)
- 8 kg/min
- 1.300 kg storage

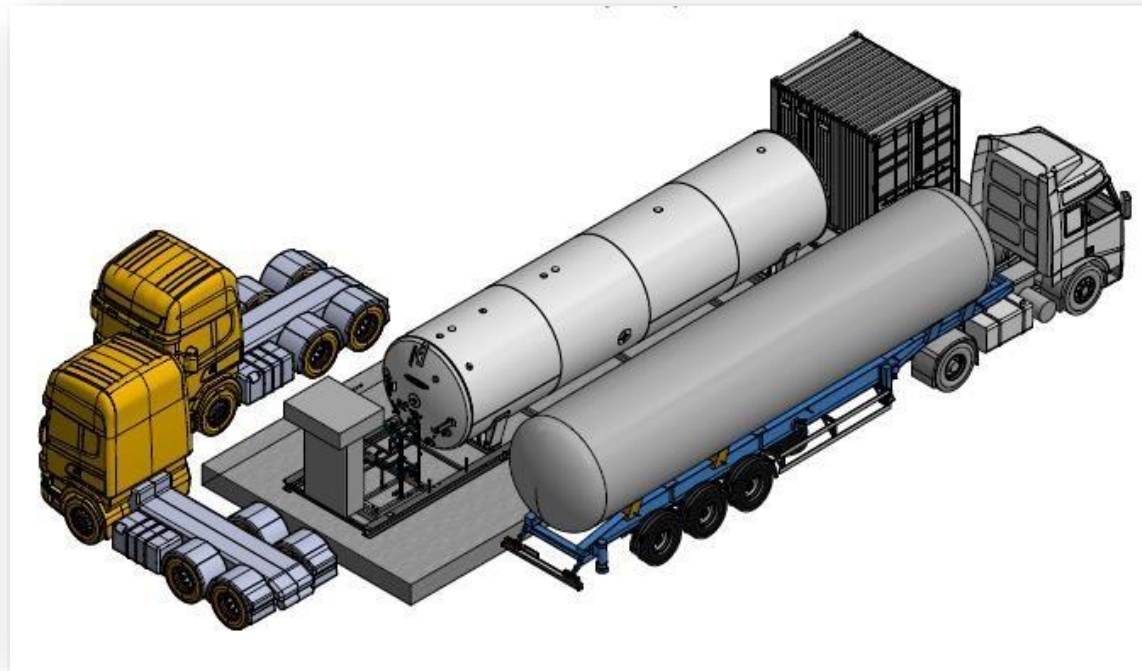

Gaseous Hydrogen Refueling:

- Liquid-to-Gas Refueling H70 (700 bar)
- Semi-mobile (skidded)
- 4.2 kg/min
- 1.300 kg storage

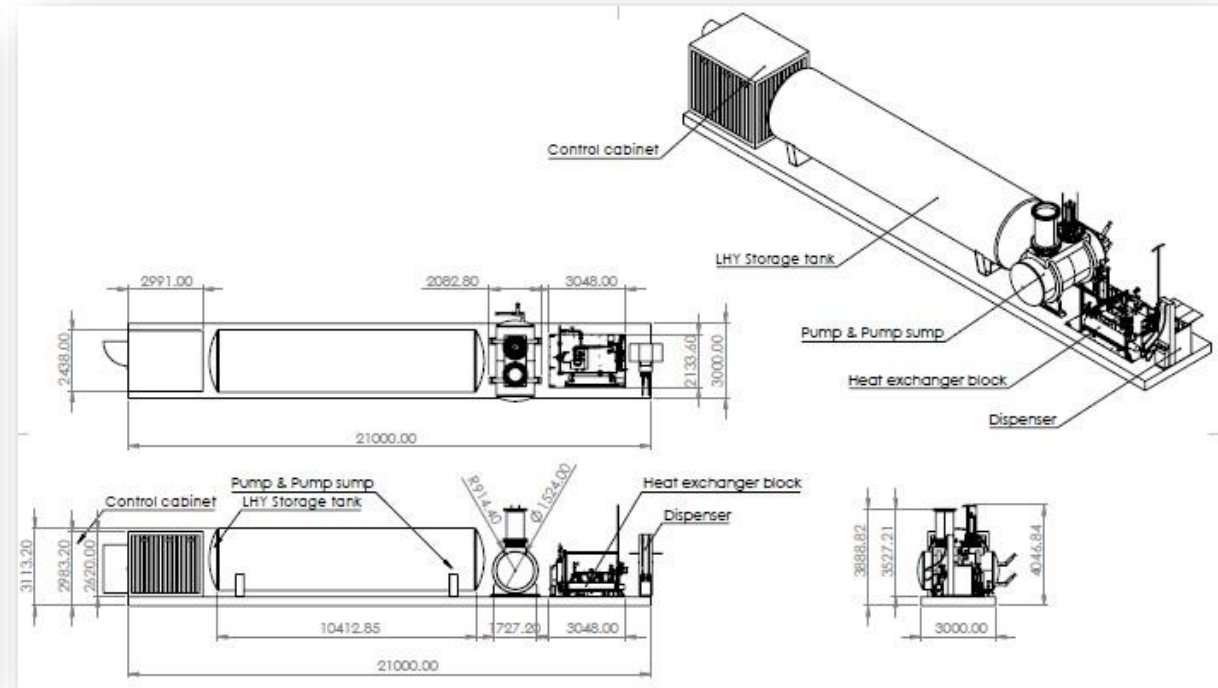

Across the Liquid Hydrogen Value Chain



McPhy

ELECTROLYSIS

PRODUCTION

TRANSFORM MATERIALS

GASIFICATION/
REFORMATION

LIQUEFACTION



INCLUDING LARGE CRYOGENIC STORAGE, BAHX, LOAD-OUT SYSTEMS



CARBON CAPTURE

SES INNOVATION
A Chart Industries Company

DISTRIBUTION



LIQUID TRANSPORT TRAILERS, ISO CONTAINERS, RAIL CARS, MARINE TRANSPORT

STORAGE

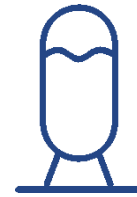

CRYOGENIC LIQUID TANKS

END USE SYSTEMS



ELECTRICITY GENERATION



AMMONIA PRODUCTION (FERTILIZERS)



REFINING



MARINE FUEL



VEHICLE FUEL STATION



FUELING SYSTEMS FOR AEROSPACE



ELECTRONICS MANUFACTURING

KEY COMPONENTS INTEGRATED WITHIN SYSTEMS

Pumps and Compressors
Flowmeters
Vacuum Insulated Piping
Valves and Sealing

Connections
Regulators
Sensors
High Pressure Storage

BALLARD

HTEC
Hydrogen Technology & Energy Corporation

FIRSTELEMENT FUEL

PLUG POWER

PARTNERS AND USERS OF HYDROGEN

HYZON



ULA
America's Ride to Space

BLUE ORIGIN

